

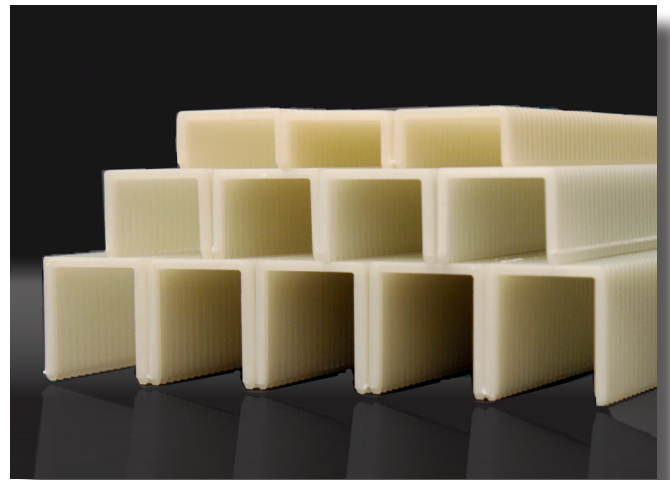

## Fastener Type

# RAPTOR® S/05 Composite 19 Gauge Staple

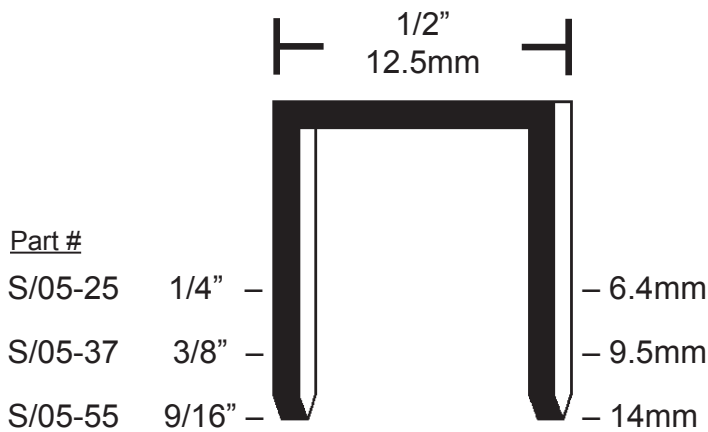

### BENEFITS

- ✓ Sawable, Sandable & Planeable
- ✓ Never Rusts or Corrodes
- ✓ Bonds Like Glue
- ✓ Completely Non-Metal

### APPLICATIONS

- Lumber wrap
- Radiant barrier installation
- House wrap

### TOOL

RAPTOR® RC-S/05



# RAPTOR® RC-S/05 Cap Stapler



In one easy step, the RC-S/05 pneumatic cap stapler drives RAPTOR® 19 gauge composite staples through the patented cap to hold thin layers of fabric paper or plastic wrap. This system provides excellent strain relief so the staple will not rip through in windy conditions and it provides resistance to water penetration at the staple entry point. It is an extremely fast, comfortable, light-weight, maneuverable, well-balanced, sturdy and durable tool, built for production applications.

The open design makes staple and cap reloading easy. The high capacity canister holds 240 caps per reel and 96 staples. The switchable trigger creates an easy transition to bump fire from sequential fire. Additionally, this tool can easily switch between stapling caps to driving staples only.

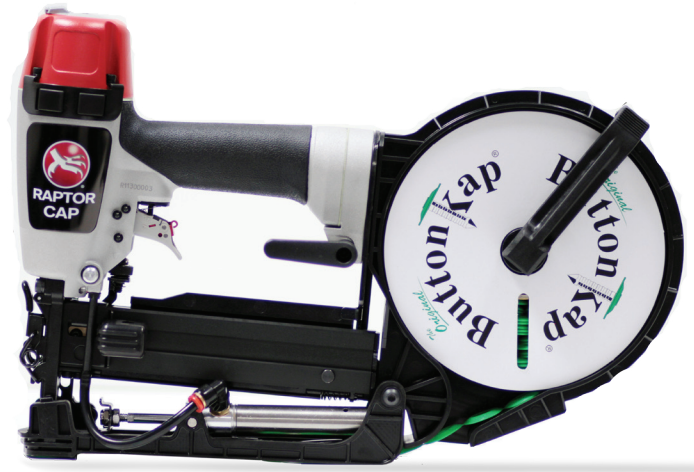

## TECHNICAL DATA

Model	RC-S/05
Magazine capacity	96 staples
Operating air pressure	70 - 110 psi (4.8 - 7.6 bar)
Dimensions LxWxH	15.5" x 4" x 10.5" (394 x 102 x 267mm)
Weight	4.8 lb (2.2 kg)
Safety	Contact & Sequential drive



<b>Button Kap® Plastic Caps</b>
Item number: RC-CAP
Caps per coil: 240
Coils per box: 10 coils
Patented design protects against tearing and water damage.

