

Fastener Type

RAPTOR® S/05 Composite

19 Gauge Staple

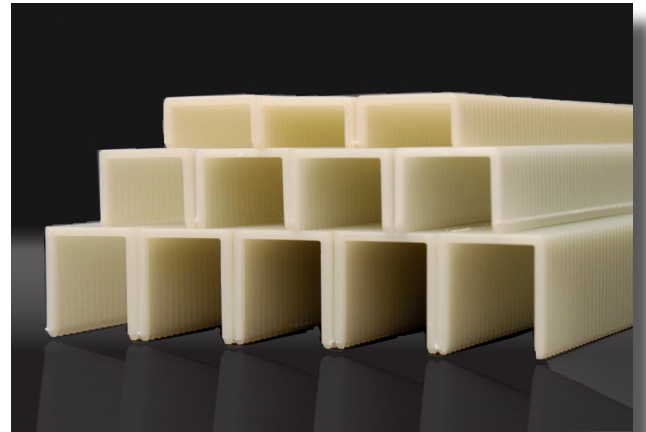
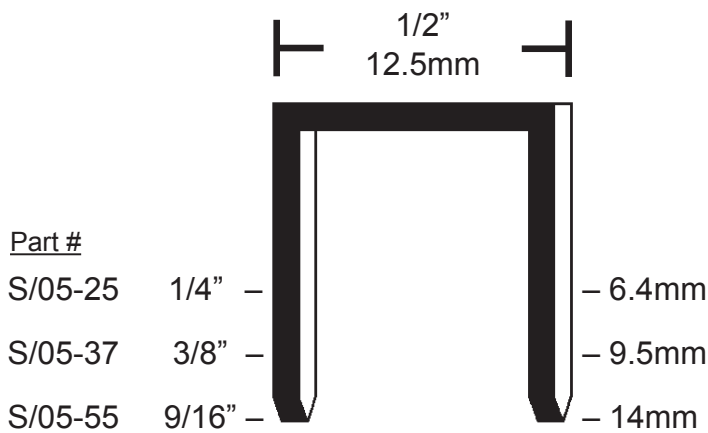

BENEFITS

- ✓ Sawable, Sandable & Planeable
- ✓ Never Rusts or Corrodes
- ✓ Bonds Like Glue
- ✓ Completely Non-Metal

APPLICATIONS

- Lumber wrap
- Lumber tagging
- Boatbuilding
- Fiberglass lay-up
- Composites manufacturing
- Radiant barrier installation
- House wrap
- Casket lining
- Casegoods tagging

TOOLS

Pneumatic:

- OMER 81P Series
- RAPTOR® S05F Series

Manual:

- RAPTOR® G11P-S/05
- RAPTOR® CT-6000P

Material Grades

Standard material: Provides best drivability but can damage high speed steel moulder knives.

LF Material: Safe for most moulder blades but drivability is somewhat compromised.

NF Material: Safe for all delicate blades but drivability is somewhat compromised.

Colors

RAPTOR® fasteners are available in colors such as White, Brown, Redwood, Cedar, Blue, Red and Gray. Please contact us for minimum order requirements and lead times.





RAPTOR

OMER 81P Series Stapler

The 81P pneumatic stapler drives RAPTOR® 19 gauge composite staples from 1/4” through 9/16”. It is extremely fast, lightweight, well-balanced and rugged.

It is offered in a standard-length magazine and a long magazine version for operators who prefer less reloading.

The 81P is also offered with a trigger safety or with a contact trip safety to reduce the possibility of accidental firing.



TECHNICAL DATA

Model	81P	81PS	81PCL	81PSCL
Magazine capacity	70 staples	70 staples	175 staples	175 staples
Operating air pressure	60 – 90 psi (4 – 6 bar)			
Dimensions LxWxH	8.5” x 1.7” x 5.8” (216 x 43 x 148mm)	8.5” x 1.7” x 5.8” (216 x 43 x 148mm)	13.8” x 1.7” x 5.8” (350 x 43 x 148mm)	13.8” x 1.7” x 5.8” (350 x 43 x 148mm)
Weight	1.9 lb (0.9 kg)	1.9 lb (0.9 kg)	2.4 lb (1.1 kg)	2.4 lb (1.1 kg)
Safety	Trigger	Contact	Trigger	Contact





RAPTOR

RAPTOR® S05F Stapler

The S05F pneumatic stapler drives RAPTOR® 19 gauge composite staples from 1/4" through 9/16". It is an extremely fast, comfortable, lightweight and maneuverable, well-balanced, sturdy and durable tool built for industrial production applications.



TECHNICAL DATA

Model	RAPTOR® S05F	RAPTOR® S05F LM
Magazine capacity	90 staples	180 staples
Operating air pressure	65 – 100 psi (4.5 – 7 bar)	65 – 100 psi (4.5 – 7 bar)
Dimensions LxWxH	8.6" x 1.7" x 5.9" (216 x 43 x 145mm)	14.8" x 1.7" x 6.2" (376 x 42 x 157mm)
Weight	1.9 lb (0.9 kg)	2.2 lb (.99 kg)
Safety	Trigger	Trigger





MANUAL STAPLERS

RAPTOR® G11P-S/05 Hammer Tacker

RAPTOR® CT-6000P Compression Stapler

The G11P-S/05 Hammer Tacker and the CT-6000P Compression Stapler drive RAPTOR® 19 gauge composite staples. These professional tools have been ergonomically designed for comfort and ease of use.

A power grip handle for the hammer tacker and an easy squeeze handle for the compression stapler allow for extended use without fatigue.

Hardened steel working parts, a retractable driver blade and a simple reloading system make either of these tools a great addition for any operator who needs a portable stapler.

G11P-S/05



CT-6000P



TECHNICAL DATA

Model	G11P-S/05	CT-6000P
Magazine capacity	140 staples	70 staples
Dimensions LxH	11.7" x 2.0" (298 x 51mm)	7.5" x 6.5" (190 x 165mm)
Weight	2.2 lb (1.0 kg)	1.1 lb (0.52 kg)
Staple Lengths Accepted	1/4"; 3/8"	1/4"; 3/8"; 9/16"

