



# Timber Processing

POLYMER COMPOSITE STAPLES

## APPLICATIONS

Lumber Wrapping  
Log Tagging  
Load Tagging  
Lumber Tagging

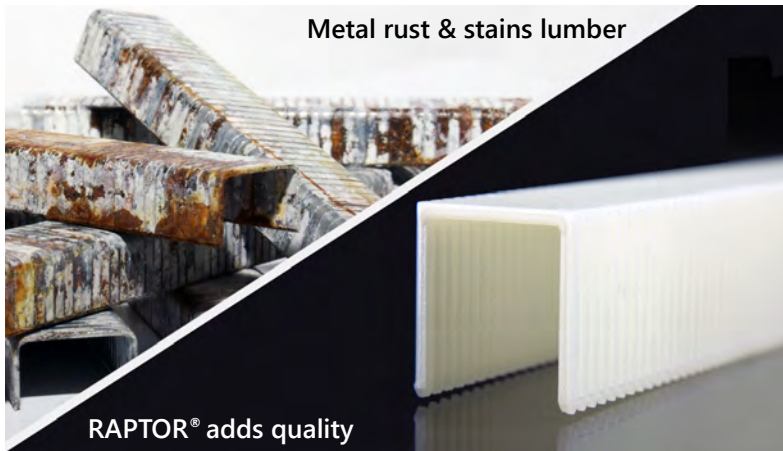

## BENEFITS & FEATURES

- ✓ Completely non-metal
- ✓ No need to remove
- ✓ Won't trip metal detectors
- ✓ Won't rust or stain lumber
- ✓ Won't damage blades or tools
- ✓ Stronger tensile holding power than similar sized metal staples
- ✓ RF & microwave safe
- ✓ Safe for kraft pulping process
- ✓ Driving performance & strength are unaffected by extreme temperatures
- ✓ No sparking hazard
- ✓ RAPTOR® staples & patented caps provide a rust free, moisture resistant strain relief fastening system for lumber wrap

## RAPTOR® S/05 Composite 19 Gauge Staples

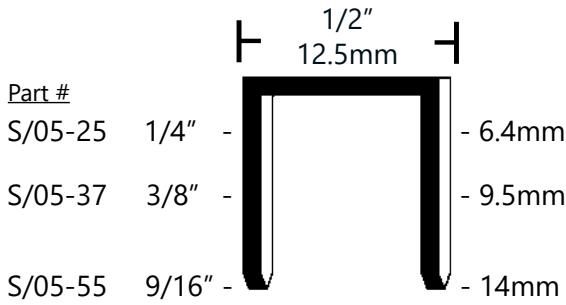

Packaging: 5040 staples per box • 20 boxes per case

## Required Tools



OMER 81P Series

\* Parts for automation options are available for OMER tools



Timber Tagger w/OMER 81P

Purchase at [www.timbertagger.com](http://www.timbertagger.com)



CT-6000P Tacker



G-3PS Hammer Tacker <9/16"

## RAPTOR® SH/05 Composite 16 Gauge Staples

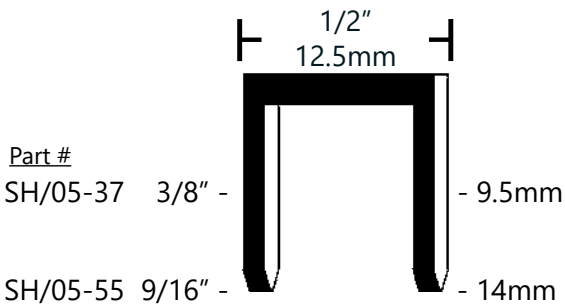

Packaging  
SH/05-37 : 5040 staples per box  
SH/05-55 : 4200 staples per box • 20 boxes per case

## Required Tools



\*OMER 82P Series



G-3PS Hammer Tacker <9/16"



CT-H7000P

## RAPTOR® SH/04 Composite 16 Gauge Staples

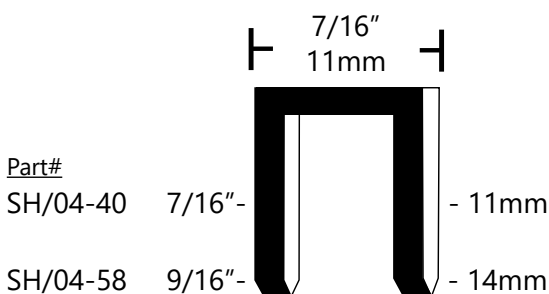

Packaging: 5040 staples per box • 20 boxes per case

## Required Tools



\*OMER 83P Series



G-3PS Hammer Tacker <9/16"



RC-SH04 Cap Stapler



CT-H7000P  
<9/16"