



Composites Manufacturing

POLYMER COMPOSITE STAPLES & CORE JOINERS



✓ Completely non-metal

✓ No need to remove

✓ Sawable, Sandable & Planeable



RAPTOR® Staples

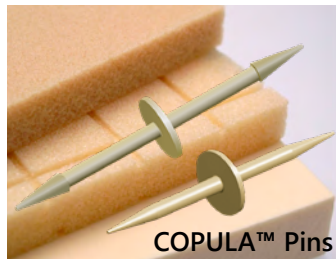

COPULA™ Pins

APPLICATIONS

- RTM / VARTM
- FIBERGLASS LAYUP
- COLD MOLDING
- SCRIMP MAT FASTENING
- FOAM & Balsa CORE JOINERY

RAPTOR® STAPLE BENEFITS

- ✓ No need to remove
- ✓ Reduces adhesive use
- ✓ No corrosion/delamination
- ✓ No holes to fill
- ✓ No outgassing from holes
- ✓ No fish eye defects

COPULA™ JOINER BENEFITS

- ✓ Securely joins core material
- ✓ Repositionable
- ✓ Not visible at the surface
- ✓ Compatible with composite resins
- ✓ Clamping & gluing are not necessary
- ✓ Less back-filling of seams or gaps



RAPTOR® S/05 Composite Staples (19 Gauge)

Required Tools



OMER 81P Series Stapler



CT-6000P Tacker

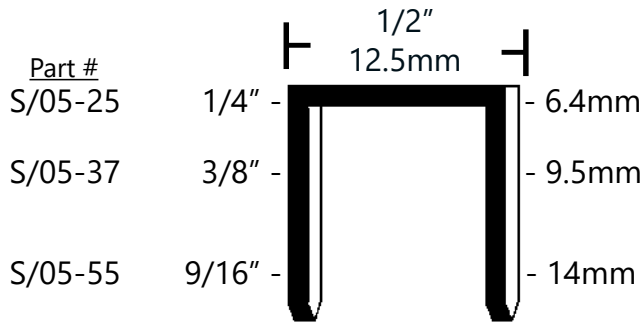

Packaging: 5040 staples per box • 20 boxes per case

RAPTOR® SH/05 Composite Staple (16 Gauge)

Required Tools

OMER 82P Series Stapler



CT-H7000P
Compression Tacker

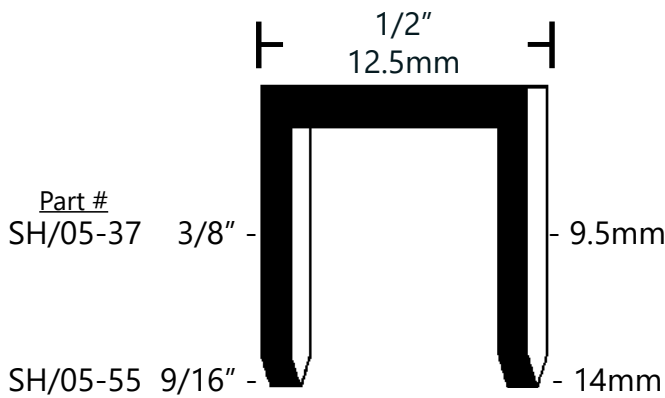

Packaging
SH/05-37 : 5040 staples per box • 20 boxes per case
SH/05-55 : 4200 staples per box

Copula™ Pins

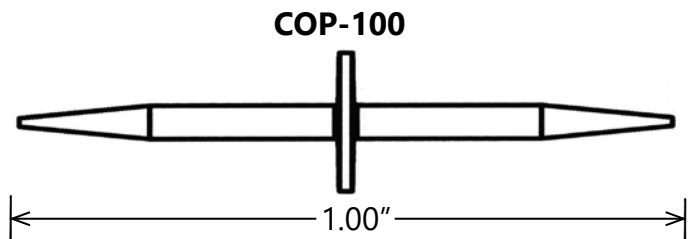
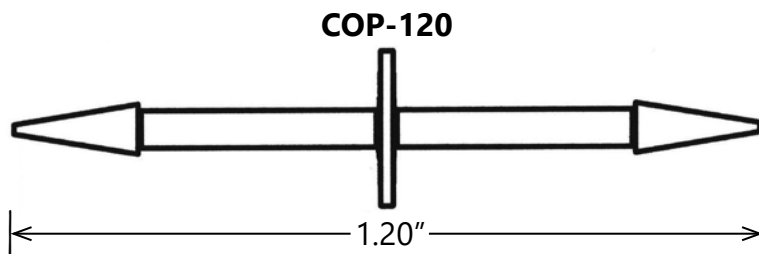

Packaging: 350 pieces per box • 20 boxes per case